



C 400H
C 500H
C 600H



PKSERWIS

PK-Serwis Spolka Jawna

Wroclaw, Ul. L. Petrzyckiego 47

52-434 Wroclaw

Tel.: +48 713634279 Faks: +48 713643267

C 400H_4000 Kg

C 500H_5000 Kg

C 600H_6000 Kg



MEASUREMENTS (mm)

		C 400H	C 500H	C 600H
Lift	h3	Lift	3600	3600
	h2	Normal free lift	100	100
Fork support		FEM 3B	FEM 4B	FEM 4B
Fork size (standard)	L x B x D	1200x140x50	1200x130x60	1200x150x60
Mast tilt angle	Forward / rear	14°/12°	14°/12°	15°/12°
Overall	L	Total length incl. fork support	3685	3780
	B	Overall width	2000	2185
Measurements	h1	Height, operational mast retracted	2800	2775
	h4	Height, operational mast extended	4450	4580
	h6	Height above safety roof	2670	2670
Turning circle	Wa	Outer	3300	3650
		Load distance x from center front axle	740	740
Working corridor width		Pallet 800 x 1200 lengthwise	5475	5825

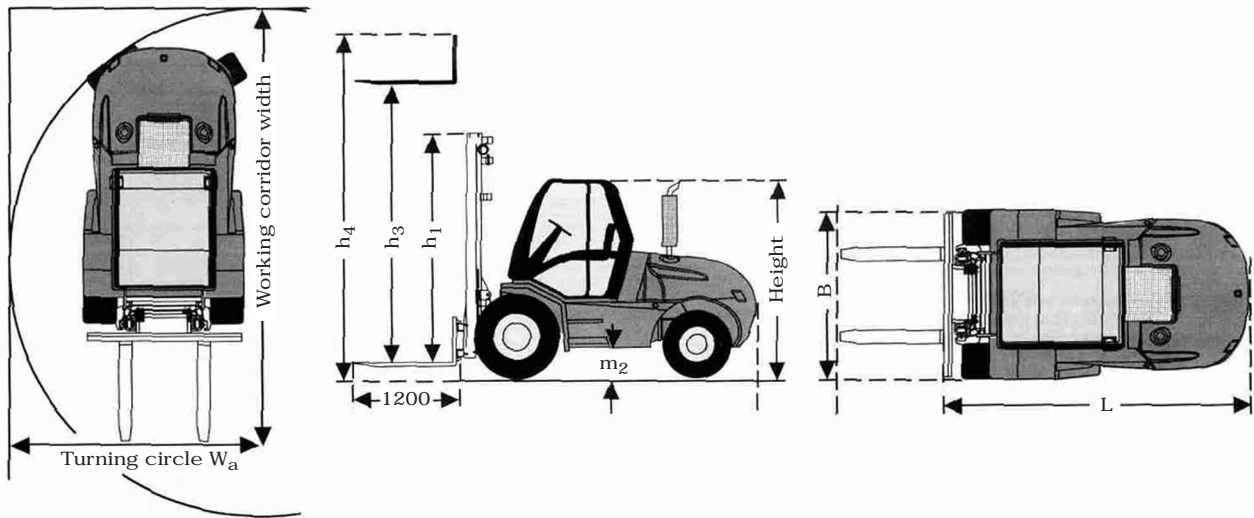

TECHNICAL SPECIFICATIONS

		C 400 H	C 500 H	C 600 H
Load capacity (Kg)	Lifting load without support	4000	5000	6000
At loadcenter	Center of gravity (mm)	600		
Lifting height	h3 (Standard duplex mast) (mm)	3600		
Combustion engine	Manufacturer/Model	Perkins 1004.42		Perkins 1004-40T
	Power acc./DIN 70020 (KW/HP)	63/86		74,5/101
	Number of revolutions (rpm)	2300		2200
	Cylinders/cubic capacity	4/4000		
	Drive unit	Diesel		
	Battery (voltage/size) (V/Ah)	12/110		
	Traction	4x4 4x2		
Steering type	Seat-steering	Hydraulic		
Gearbox	Type/steps	Hydrostatic, 2 automatic		
Gearshift	Type/steps	Load-dependent, automatic		
Unladen weight (Kg)		8350	8850	10170
Axle weight (Kg)	Without load front / rear	3950/4400	4050/4800	4710/5460
	With full load / without load)	30/35	28/35	
Speeds	Driving with/without lifting load (Km/h)	20/20		17/20
	Lifting with/without load (m/s)	0,43/0,50		0,23/0,36
	Lowering with/without load (m/s)	0,48/0,38		0,42/0,40
Tyres	Front	16/70 x 20		18-19,5 16 PR
	Rear	11,5/80 x 15,3 (8,25/80 x 15 opt.)		305/70 R 19,5 (265/70 R 19,5 opt.)
Ground Clearance	m1 At deepest point (mm)	260		280 bis 310
	m2 Half Wheelbase (mm)	380		400
External turning circle	Wa (mm)	3300		3650
Service brake	Hydraulic, power assisted			
Parking brake	Hydraulic			
Working pressure (bar)	180			
Sound level	Average at driver's ear (dB)(A)	78		79

AUSA reserves the right to make any changes in the specifications without prior notice.