



GSB-15

GSB-20

Grilled Screening Bucket

For 13 to 30 t carriers



Grilled Screening Bucket

For 13 to 30 t carriers

Applications:

Ideal for specialised works such as:

- ▶ Sorting demolition material for reuse in roads, trenches...
- ▶ Cleaning stony terrain

Advantages:

- ▶ 3 easy interchangeable grills available (50x200, 28x100, 50x50 mm)
- ▶ Complete structure made in Hardox 400, for improved durability
- ▶ High productivity with the high speed alternate jumping movement of the grills
- ▶ Increased durability thanks to the safety valve protecting the hydraulic circuit of the bucket (pressure and flow)
- ▶ Low level of vibration transmitted to the carrier boom



MODEL		GSB-15	GSB-20
A	mm	1200	1500
B	mm	1290	1410
C	mm	1220	1430
D	mm	1000	1187
Oil Flow	l/min	130	130
Pressure	bar	230	230
Capacity	l	750	1400
Weight	kg	1200	1650
Excavator Weight	ton	13/20	20/30

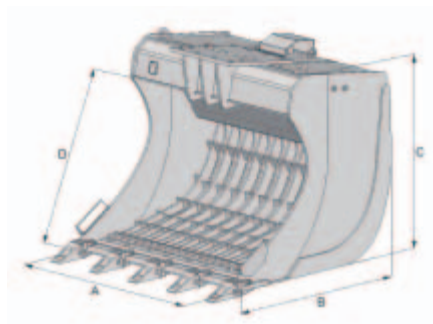

3 screen sizes:

- 50 x 200 mm
- 28 x 100 mm
- 50 x 50 mm
- Other sizes upon request



Montabert SAS

203, route de Grenoble
69800 St Priest, France

Tel. +33-(0)4 72 22 97 97 Fax. +33-(0)4 72 22 97 56
montabert_marketing@eu.irco.com

www.montabert.com

Nothing contained in this brochure is intended to extend any warranty or representation expressed or implied, regarding the products described herein. Any such warranties or other terms and conditions of sale products shall be in accordance with Ingersoll Rand standards terms and conditions of sales for such products, which are available upon request. Specifications and machines can be modified at any time and without notice.